

OLD CONCEPT KNOW IN THE ART

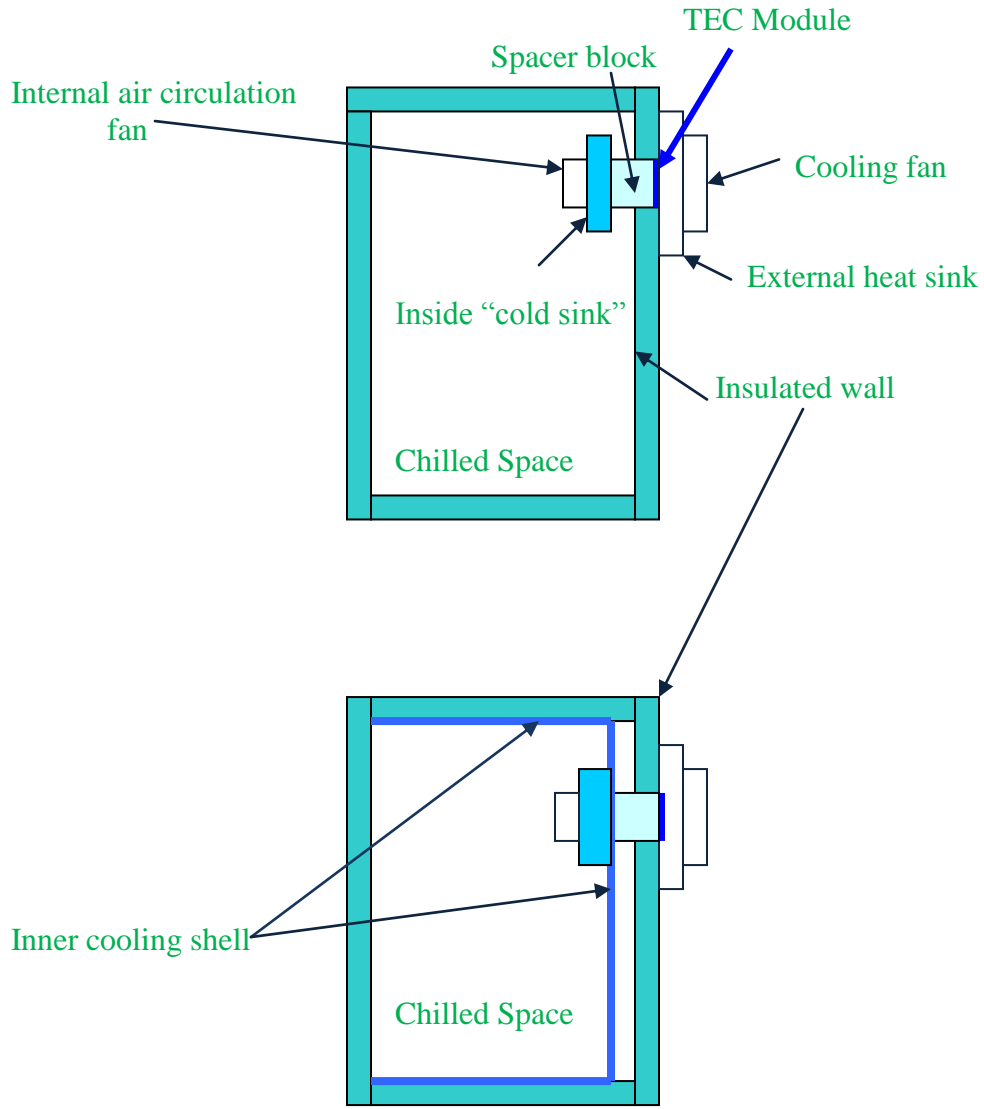

NEW

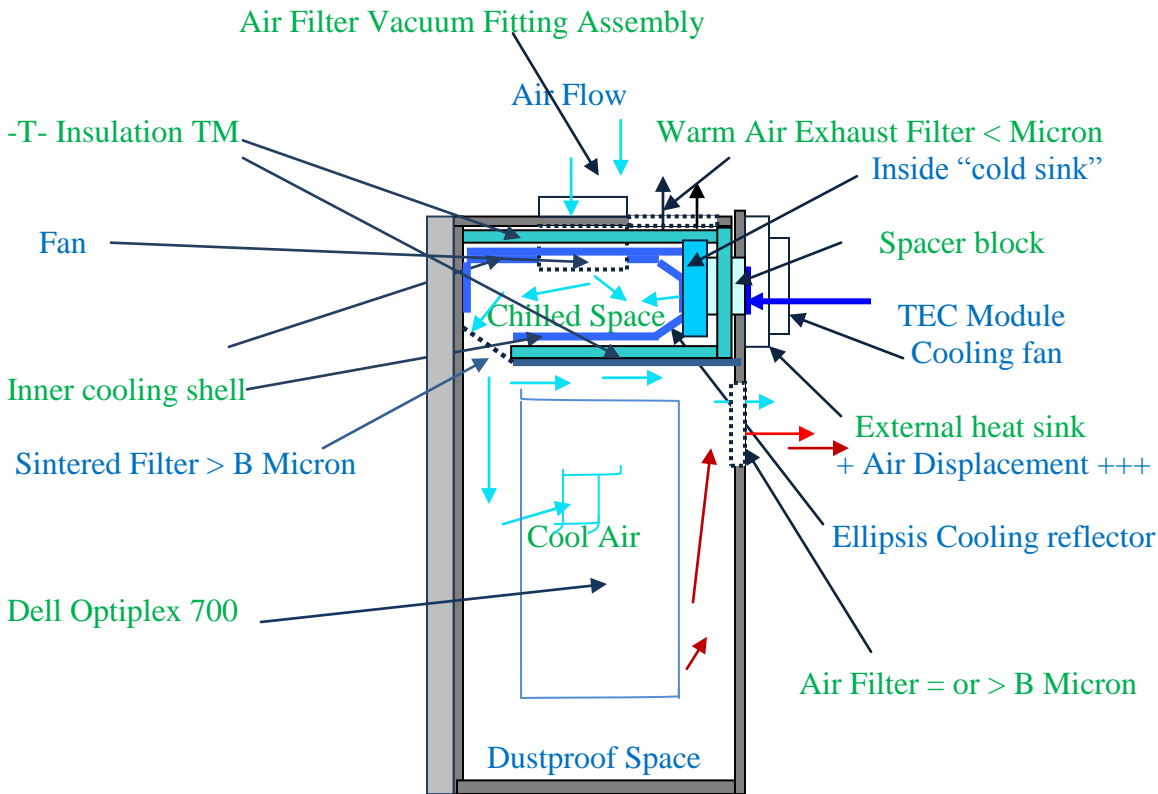

Manual

P/N: Single Set-point Ver. 1.0
Temperature Controller

Date: 10-30-08

UE P/N: DE97038- T1000- DTLSP

General Instruction :

This is a switching temperature set point controller for cooling the Valley Plastics Tm PC Computer Cover upper duct section, operating on 12 VDC, with three-digit LED display. (Shown in the drawing above). The set-point control capability can switch on and switch off the 12 VDC, 12 amp electrical supply output to TEC module shown in photo below.

The NTC sensor is placed into the lower section of the Valley Plastics TM Computer enclosure whose temperature is to be monitored. It can work in air/gas environments. The sensor tip is mounted flush with the back surface wall of the cabinet interior where your PC is enclosed. Once the circuit is energized, the 7- segment LED displays the default set-point temperature. If the initial

Copy Write 2008 Thompson Plastic And Chemical AG
Patent Pending

actual temperature exceeds the initial default set-point temperature, power output to the TEC module remains “off” So when you install your PC Tower unit, flat screen monitor, or laser printer you will need to set the default temperature above room temperature. The DC fan located attached to the TEC cold plate is energized only when the TEC module is energized However, the cold plate is side of the peltier junction device will radiate its cold cooling power through conduction to Ellipsis the ellipsoidal composite metal reflector located on the upper duct section and that conduction will also flow through the metal lining of the upper duct section and to the aluminum intake fan’s housing as shown in the drawing above. Upper section is insulated with insulation or composite foam-SI polymerized sheet, extrusion, or sandwich with high Rh factor which allows the TEC to

. The calculations are easy. TEC heat extractor #1 devotes 232 units of cooling power to off-setting heat leakage – and 268 units to temperature reduction with just simple insulation. If we add a #2 additional TEC modual you get more possibilities (more cooling). User can use the 3 set keys below the LED Display window to change the controlled temperature. Dusty environments benefit because the Valley Plastic TM PC Covers when air conditioned keep the environment even cooler than the traditional Fan cooling model. This allow for the use of the sintered plastic air filers or varying pore sizes or The Valley TM composite air filter which uses the Dupont Hybrid membrane filter technology.

Electronics Instruction :

- 1. Input: DC12V, 12A Max.**
- 2. Output: 10A to TEC module, 0.9A to DC fans**

TEC Modual:

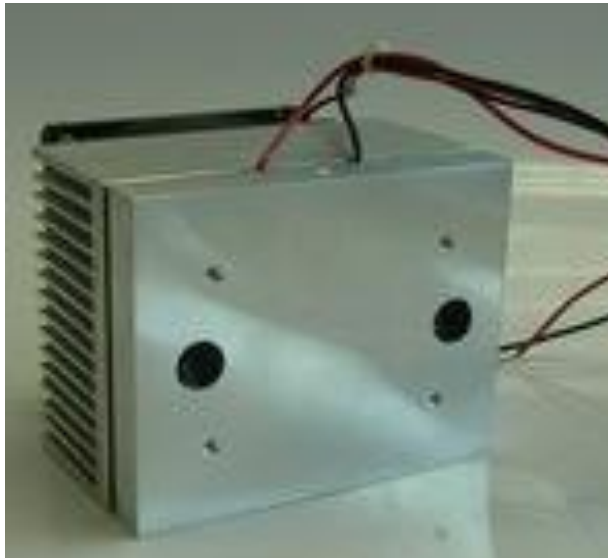

Acclaimed Review :

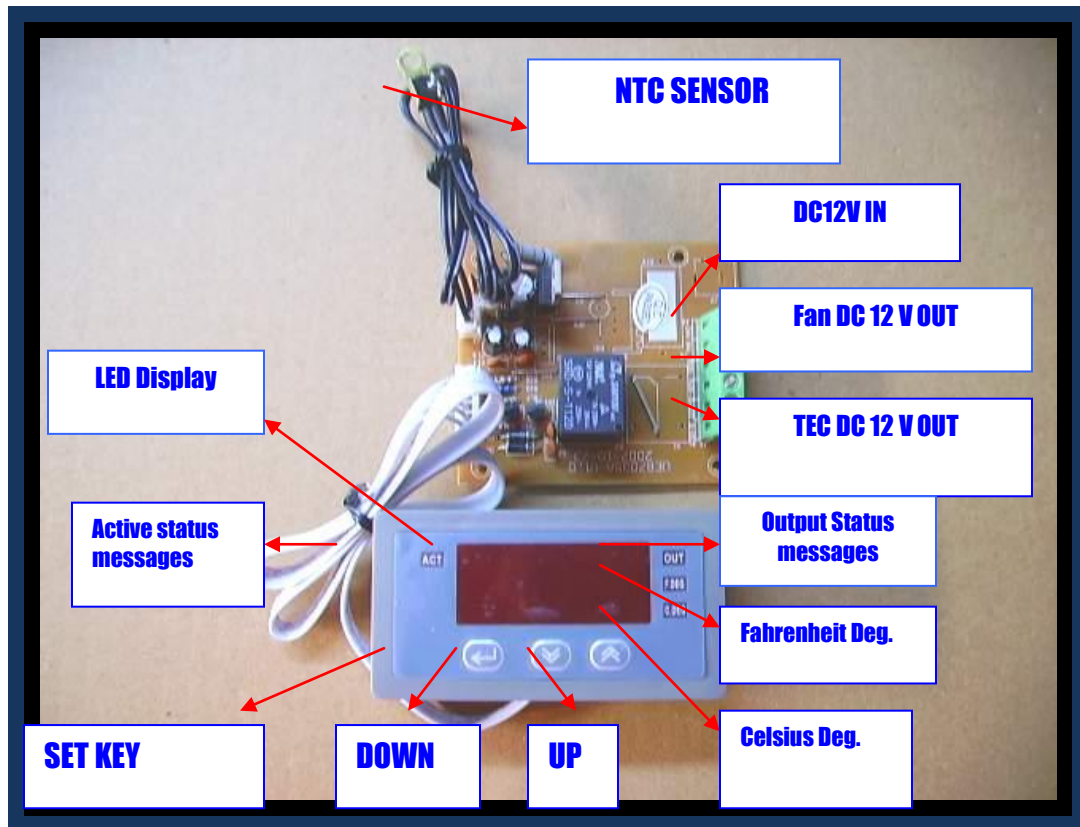

Figure 1 Door Mounted Digital Temp. Controls

3 Default: When first energized, the circuit is in set-point mode, displaying the default set-point. **4 Micro-Switches:**

- (1) Set Key:** Click once, and the program enters the temperature set-point set-up mode, with the 7-seg. LED initially displaying the default set-point. User can press the UP or DOWN key to change the set-point temperature. Click "SET" key a second time, and the program will exit the program mode, and the LED display will revert to displaying the current actual

**Copy Write 2008 Thompson Plastic And Chemical AG
Patent Pending**

temperature at the NTC sensor. When in temperature sensing mode, the “Active” status LED will be illuminated. If the temperature detected by the NTC sensor is under the set-point temperature, the DC outputs to the TEC module and fan are not energized. If the detected temperature exceeds the set-point temperature, the DC outputs to the TEC module and fan will be energized.

- (2) **UP Key:** Click once, and the set-point temperature increases by 1 (or 1 Degree F). The maximum set-point value is +85 (or 185 Degree F).
- (3) **DOWN Key** Click once, and the set-point temperature decreases by 1 (or 1 degree F). The minimum set-point value is -20 (or 0 Degree F).
- (4) To shift between Celsius and the Fahrenheit degrees, user should simultaneously depresses the SET and UP keys – and the display will switch to the other system.

Note

- (1) Do not touch the PCBA circuit while the module is run.
- (2) For both the TEC output power wires, and the main DC input power wires to the circuit, AWG 18 wire is suitable when the TEC module is under 6 Amps, AWG 16 wire is required while the TEC module is from 6 to 8 Amps, and AWG 14 wire is required while the TEC module exceeds 8 Amps.

Summary for the IT Engineers, Corporate Management, and all other polymer science challenged individuals

Out with the old in with the new. This is the way to solve a problem and not become part of the problem. We encourage you to shop around but the the TEC Modul is necessary to get the .03 micron particle efficiency and a reasonable cost to benefit ration per PC. Just to give you an idea carbon dust is 1 micron in size and the visable dust you can see is about 10 microns.

IT People, I know most of you want to take a Playboy approach to solving the Computer dust problem and in some cases carbon dirt that is shorting out your hard drives. However, If you are not too savvy on polymer science or plastics in particular you know about TEC to chill computer case right? With our plastic insulation the TEC has more power to cool the air which allows the Dupont Hybrid membrane technology filters with 0.03 micron particle filtration to be used. The true Solution for mining ore dust, conductive carbon dust, and H2o gas (H2SO4 acid corrosion or motherboard and silver whiskering) is Thompson Plastic And Chemical Company's Valley Plastics TM PC NEMA 4 PC computer enclosure system. Otherwise the cost benefit ratio would be just too high for a \$1500 Computer.

- **Pleated or stand alone polyester prefilters**
- **Dupont hybrid membrane technology**
- **Scrim backing for underside for easy visual check on main filter life**
- **Square configuration to fit vacuum fitted air filter in front of intake fan**
- **Positive air flow or positive displacement creates an air seal and 1 single entry point**
- **Air flow through intake entry point is pre-filter to 0.03 micron particle size**
- **Dust holding capacity of the mechanical pre-filter technology has high dust holding capacity over electrostatic pleated air filters used by our competitors**
- **3 Valley Pore TM filters per case**
- **Upper duct section with top mounted intake fan**

**Copy Write 2008 Thompson Plastic And Chemical AG
Patent Pending**

- **1-2 TEC Thermoelectric Cooling Module(s) located in upper duct**
- **Ellipsis - a radiant cold reflector and Inner Cooling Shell create a chilled air space in the eye of the upper chamber**
- **Valley Pore #1 filter micron pore size allows the chilled filtered air to flow into the lower chamber for your Dell Optiplex PC to run smoothly**
- **Valley Pore #2 filter is a smaller pore size than #1 and allows heat energy to escape from upper chamber**
- **Valley Pore #3 filter allows air to flow out of the lower chamber through the positive air flow created and prevents any reverse air flow from mining metal ore dust or chemical vapors**
- **The dustproof space created can be chemical vapor proof with the use of active carbon or aluminum absorber cartridges in the upper duct and Vapor Phase emitter VPCLR technology in the lower chamber when the Valley Pore #3 is of a small pore size**
- **The Axial tube type fan is the perfect solution.**

Prepared by : Alicia Borlin

Checked by: Kate Hearst